

Service Schematics

NOKIA N79

Introduction

RM-348

IMPORTANT:

This document is intended for use by authorized NOKIA service centers only.

“Service Schematics” was created with focus on customer care.
The purpose of this document is to provide further technical repair information for NOKIA mobile phones on Level 3/4 service activities.
It contains additional information such as e.g. “Component finder”.

Saving process time and improving the repair quality is the aim of this document.
It is to be used additionally to the service manual and other training
or service information such as Service Bulletins.

While every endeavour has been made to ensure the accuracy of this document, some errors may exist. If the reader finds any errors, NOKIA shall be notified in writing.

Please send E-Mail to: TrainingAndVendor.Development@nokia.com

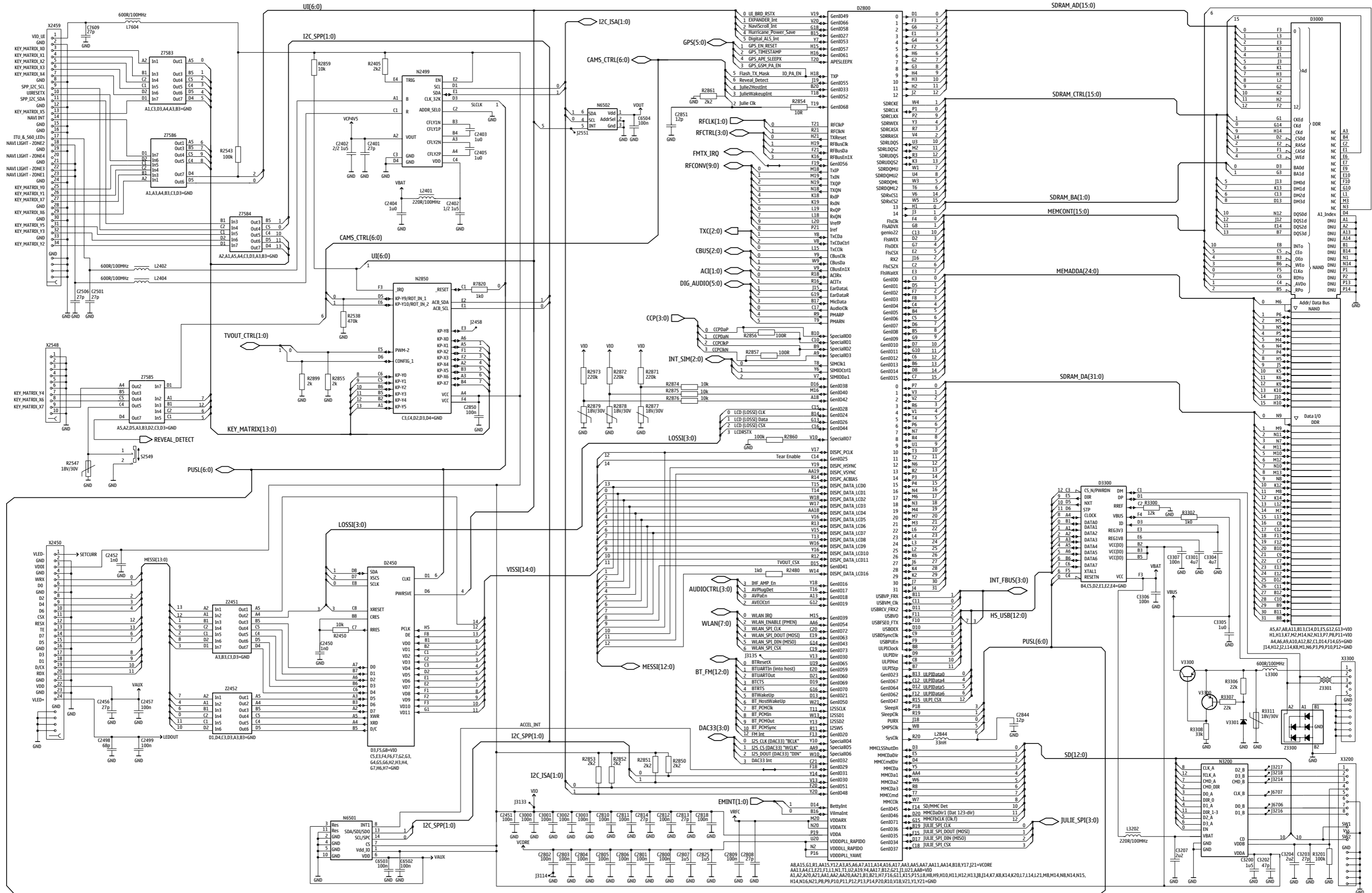

Table of Contents

Front page	1
RAPIDO, USB, memory, SD	2
Betty, AVilma, Audio, Video	3
Application Processor, Camera	4
BTHFM, WLAN	5
RF part	6
User Interface (UI)	7
Component finder	8

Copyright © NOKIA

This material, including documentation and any related computer programs is protected by copyright, controlled by NOKIA. All rights are reserved. Copying, including reproducing, modifying, storing, adapting or translating any or all of this material requires the prior written consent of NOKIA. This material also contains company confidential information, which may not be disclosed to others without the prior written consent of NOKIA.



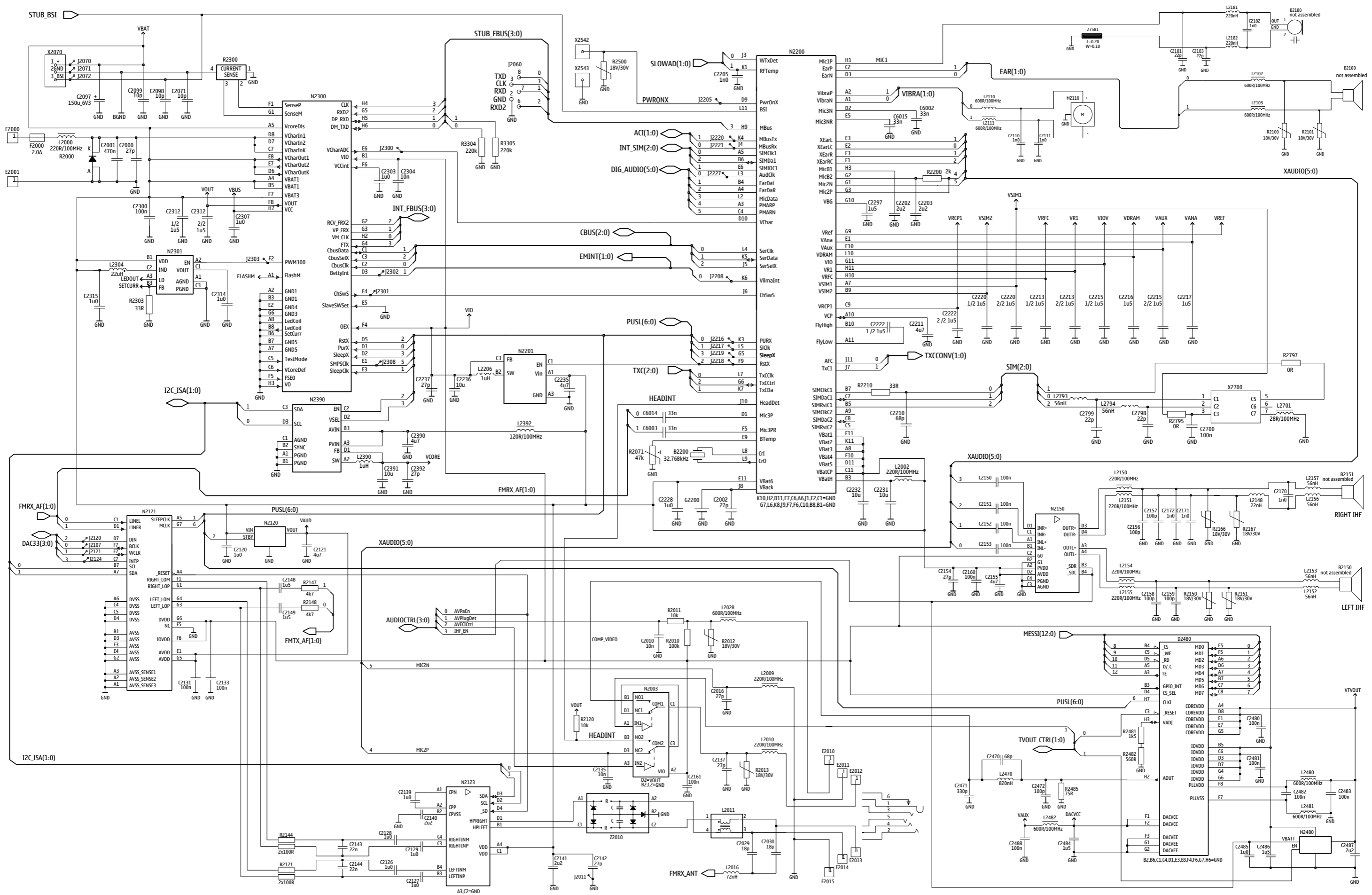

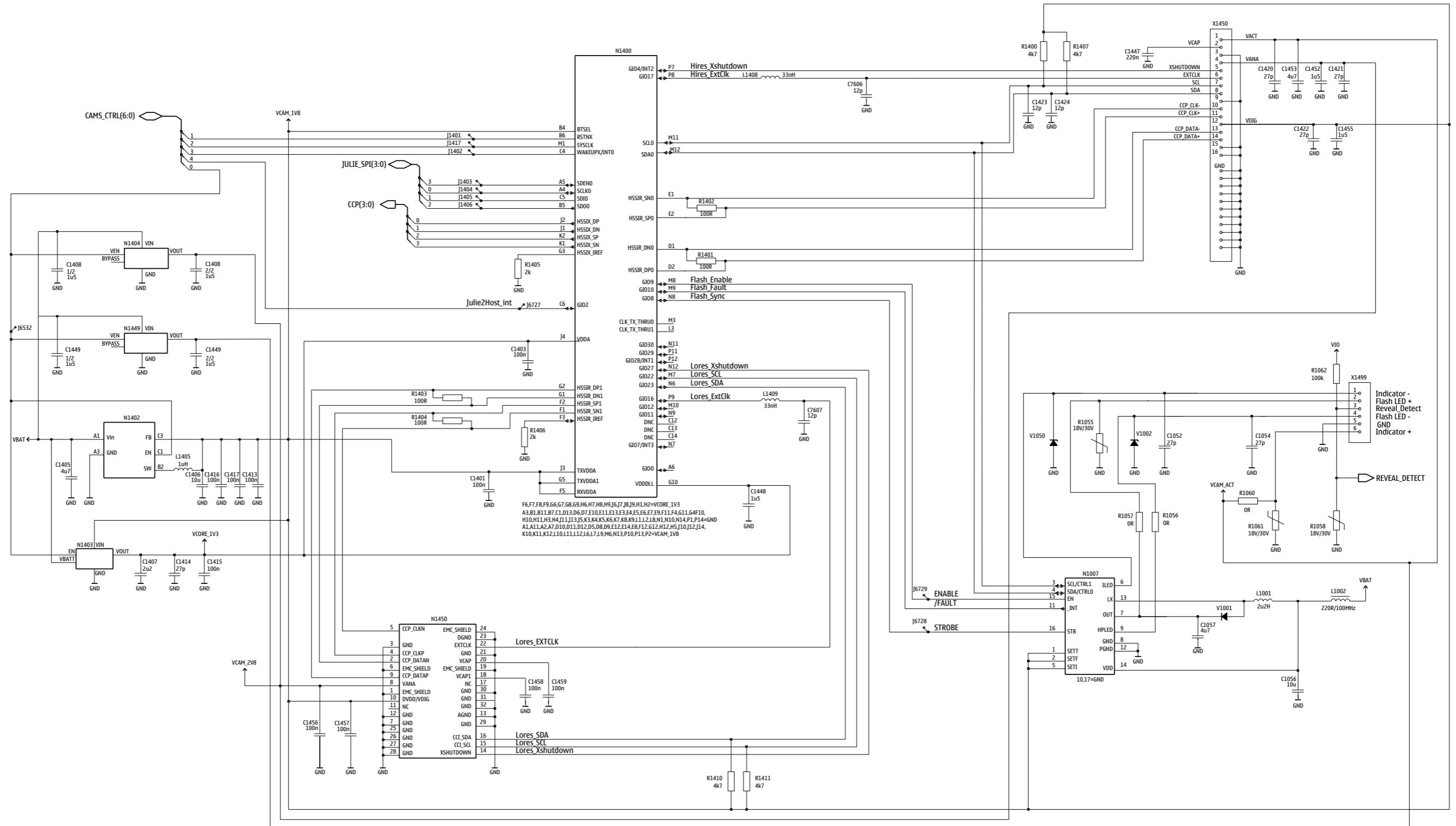

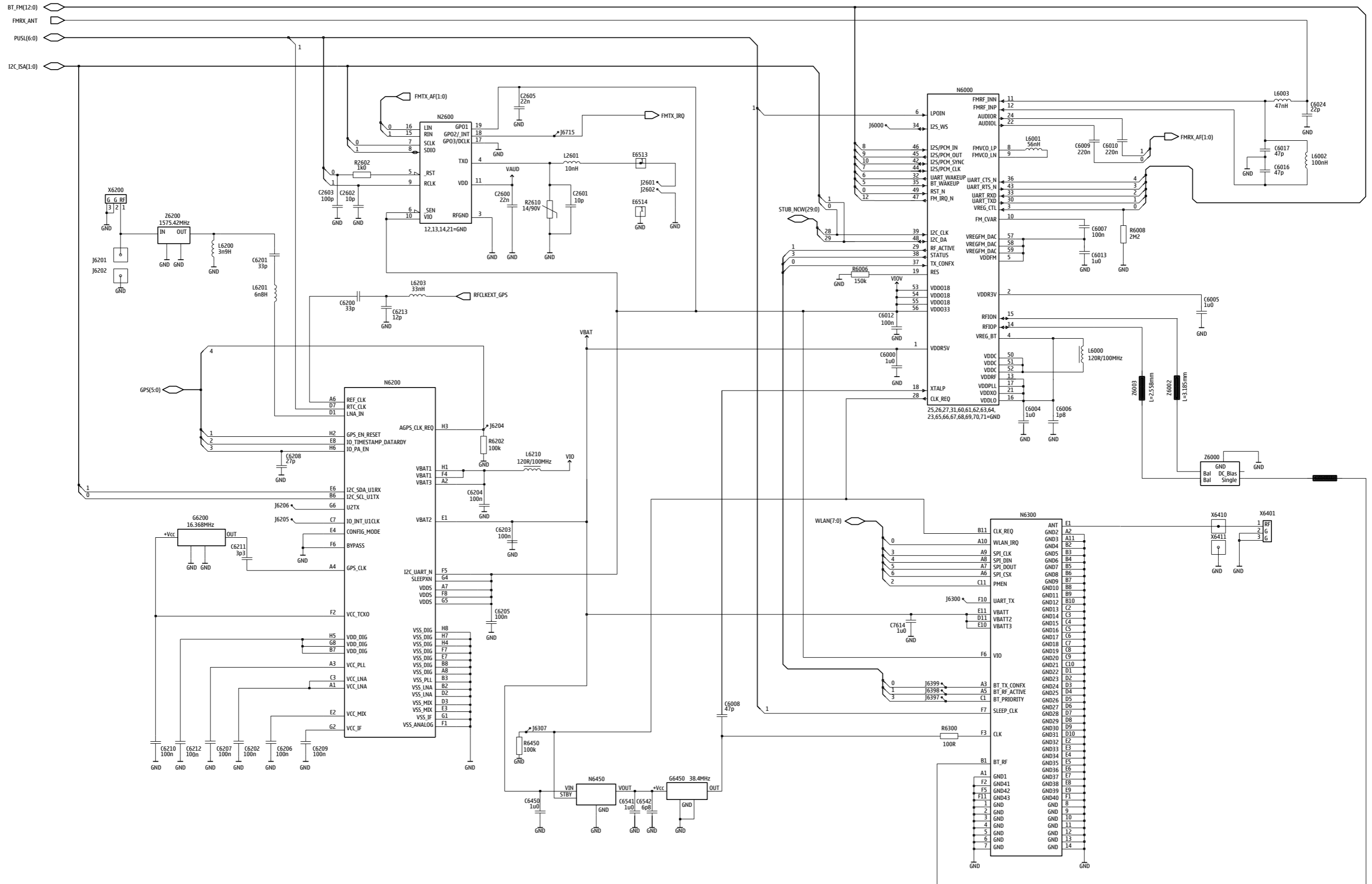

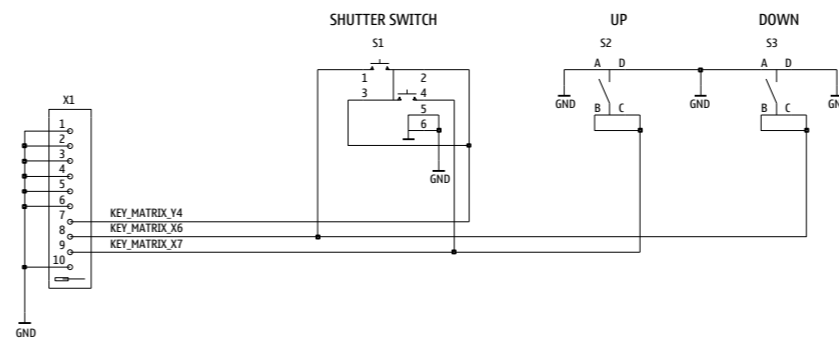
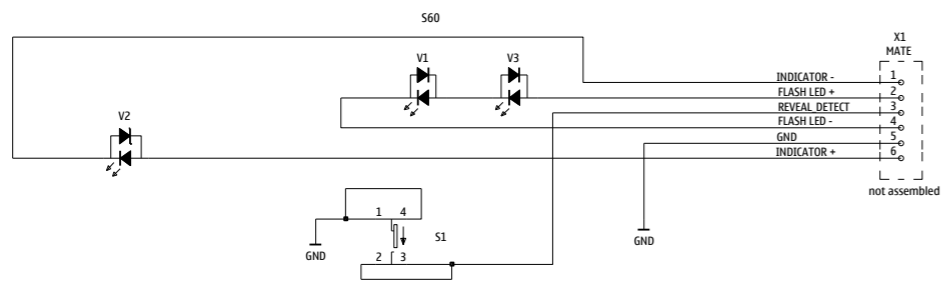
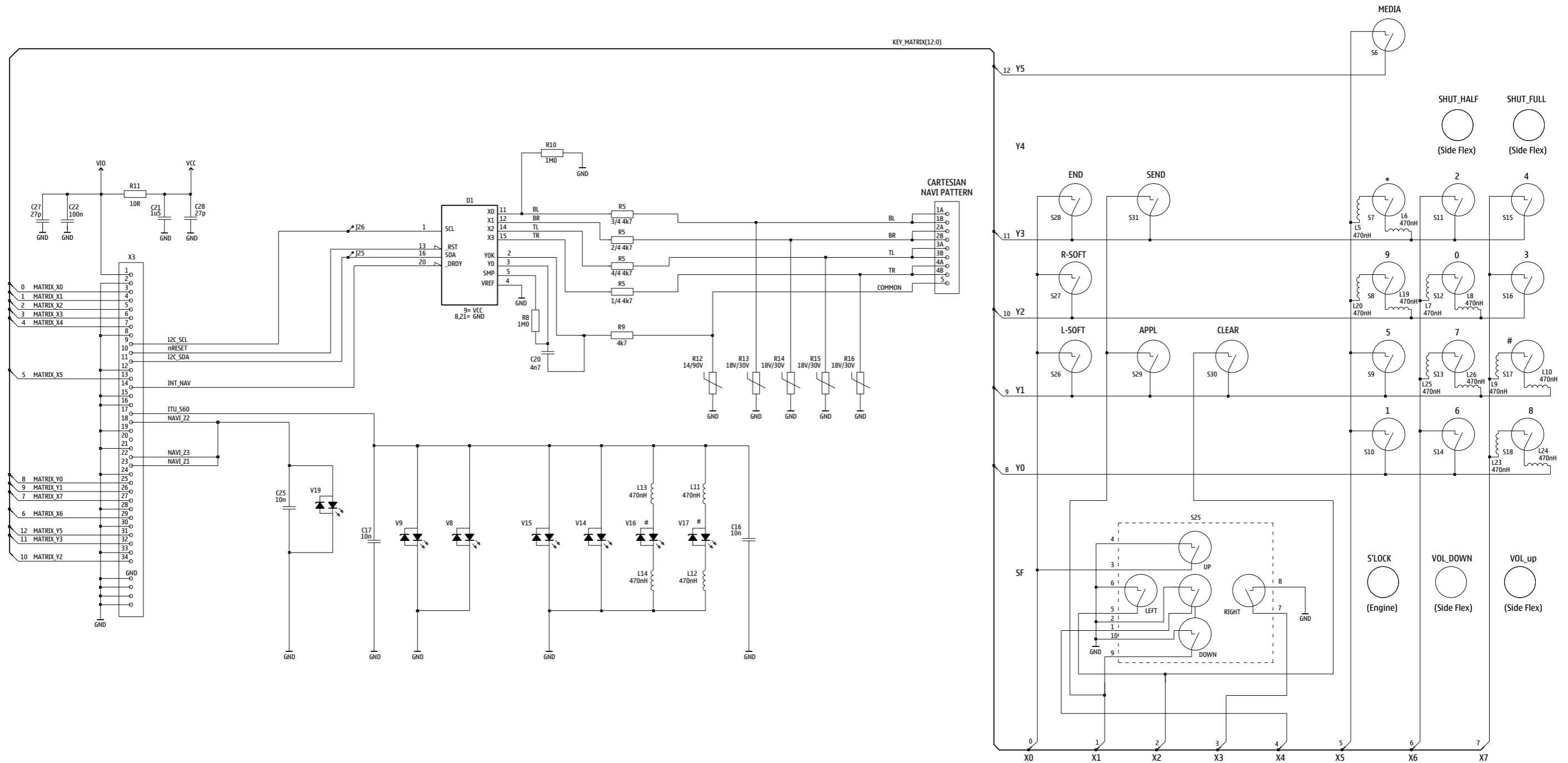

A	C2154	L5	C2605	K8	C6504	T2	L2010	S6	N2121	M7	R2547	T7	X2450	I2	
A3300	07	C2155	M5	C2700	R7	C6541	P2	L2011	S6	N2123	M7	R2602	K9	X2459	G2
A6200	S7	C2156	L4	C2798	R7	C6542	P2	L2016	S3	N2150	L5	R2610	K9	X2542	T4
A7500	E5	C2157	L4	C2799	R8	C7500	E2	L2028	S6	N2200	J5	R2795	Q7	X2543	T3
B	C2158	L4	C2800	H6	C7507	E3	L2102	S6	N2201	J9	R2797	Q8	X2548	L1	
B2200	J5	C2159	L4	C2801	H6	C7513	D2	L2103	S6	N2300	K7	R2850	G5	X2700	Q7
C	C2160	L5	C2802	H6	C7518	D4	L2110	K6	N2301	J2	R2851	G6	X3200	P8	
C1052	01	C2161	S7	C2803	G6	C7519	D2	L2111	K6	N2390	J7	R2852	I5	X3300	Q9
C1054	02	C2170	B2	C2804	I5	C7520	D2	L2148	B2	N2480	K4	R2853	G5	X6410	U2
C1056	03	C2171	C2	C2805	I6	C7521	D7	L2150	L4	N2499	M2	R2854	G4	X6411	U2
C1057	N2	C2172	C3	C2806	G4	C7523	F6	L2151	L4	N2600	K9	R2855	H4	X7500	C4
C1401	N4	C2181	C6	C2807	G4	C7524	D5	L2152	S3	N2850	I4	R2856	I5	X7501	C5
C1403	N4	C2182	A7	C2808	H4	C7525	D5	L2153	R3	N3200	M8	R2857	I6	X7502	C4
C1405	M3	C2183	C7	C2809	H4	C7543	D8	L2154	L4	N6000	S5	R2859	I4	X7531	C6
C1406	M4	C2202	J6	C2810	I6	C7544	D8	L2155	L4	N6200	S7	R2860	G6	Z	
C1407	M4	C2203	J6	C2811	G6	C7545	D9	L2156	A3	N6300	R2	R2861	G5	Z2010	R6
C1408	N6	C2205	J6	C2812	G5	C7547	D9	L2157	B3	N6450	P2	R2871	C2	Z2451	J3
C1413	N6	C2210	L5	C2813	I4	C7548	E9	L2181	B6	N6501	L7	R2872	D2	Z2452	J3
C1414	M5	C2211	K4	C2814	I5	C7549	E8	L2182	B7	N6502	T2	R2874	D2	Z3300	O8
C1415	M5	C2213	J4	C2818	H4	C7550	D9	L2206	I8	N7505	E3	R2875	D2	Z3301	O8
C1416	O4	C2215	J5	C2825	G5	C7553	E8	L2304	J1	N7520	E6	R2876	D3	Z6000	S4
C1417	M4	C2216	J5	C2844	G4	C7580	D2	L2390	J8	N7540	E8	R2877	C2	Z6200	T8
C1420	R6	C2217	K6	C2850	I4	C7581	D2	L2392	J7	N7541	D8	R2878	C1	Z7501	D4
C1421	Q6	C2220	K5	C2851	G4	C7582	D2	L2401	M2	N7590	E4	R2879	D3	Z7503	E4
C1422	P3	C2222	K5	C3000	I8	C7583	D3	L2402	M2	R	R2899	H4	Z7504	E4	
C1423	P6	C2228	K5	C3001	I9	C7590	F4	L2404	M2	R1055	O2	R2973	D3	Z7521	F6
C1424	O6	C2231	K6	C3002	G9	C7591	E4	L2470	L3	R1056	O2	R3201	M9	Z7540	F7
C1447	R6	C2232	K4	C3003	H6	C7606	O4	L2480	K4	R1057	O2	R3300	O8	Z7541	E7
C1448	N6	C2235	J9	C3200	M8	C7607	O5	L2481	K4	R1058	P2	R3302	O7	Z7580	D4
C1449	M6	C2236	J8	C3202	M8	C7609	H2	L2482	K2	R1060	N2	R3304	L8	Z7582	F3
C1452	Q6	C2237	J8	C3203	P8	C7614	P3	L2601	L9	R1061	O2	R3305	K8	Z7583	H4
C1453	R6	C2297	J5	C3204	M9	D	L2701	Q7	R1062	N2	R3306	O7	Z7584	G4	
C1455	P3	C2300	J7	C3207	M9	D2450	J4	L2793	Q8	R1400	Q6	R3307	P6	Z7585	L2
C1456	T3	C2303	K8	C3301	O6	D2480	K3	L2794	Q7	R1401	N4	R3308	P8	Z7586	G4
C1457	T3	C2304	J7	C3304	P7	D2800	H5	L2844	G4	R1402	N4	R3311	P8		
C1458	T4	C2307	L7	C3305	O6	D3000	H8	L3202	M9	R1403	N4	R6006	R4		
C1459	T2	C2312	K8	C3306	P8	D3300	O7	L3300	P8	R1404	N4	R6008	R3		
C2000	C7	C2314	J2	C3307	O8	E	L6000	S5	R1405	N3	R6202	S6			
C2001	C7	C2315	K2	C6000	S5	E1000	H9	L6001	S4	R1406	N3	R6300	P3		
C2002	M8	C2390	J7	C6002	K6	E2000	D9	L6002	S4	R1407	O6	R6450	P2		
C2010	S7	C2391	I7	C6003	K6	E2001	C9	L6003	S3	R1410	O4	R7501	E2		
C2016	T7	C2392	I6	C6004	S5	E2010	T5	L6200	T8	R1411	O4	R7502	D3		
C2029	S4	C2401	M2	C6005	S5	E2011	U5	L6201	S8	R2000	C7	R7503	D3		
C2030	S4	C2402	M2	C6006	R4	E2012	T6	L6203	E2	R2010	S7	R7509	E3		
C2071	D7	C2403	M2	C6007	S4	E2013	S5	L6210	R6	R2011	S7	R7522	E4		
C2097	L6	C2404	L2	C6008	P3	E2014	S6	L7500	D4	R2012	S6	R7523	D6		
C2098	D7	C2405	M2	C6009	M6	E2015	S4	L7501	D4	R2013	S7	R7524	D6		
C2099	D8	C2450	I3	C6010	M6	E6513	M9	L7502	F4	R2071	I4	R7525	D5		
C2110	L6	C2451	J4	C6012	S5	E6514	D2	L7503	D3	R2100	S6	R7526	D5		
C2111	K6	C2452	H2	C6013	R5	E7820	C3	L7506	F3	R2101	S6	R7527	D6		
C2120	L6	C2456	J2	C6014	K6	E7821	C2	L7510	F7	R2120	S7	R7528	F6		
C2121	M6	C2457	J2	C6015	J6	E7822	D3	L7540	D8	R2121	M8	R7541	D9		
C2126	M7	C2470	L3	C6016	S4	E7823	D2	L7550	D9	R2144	M8	R7543	E8		
C2127	M7	C2471	L3	C6017	S4	F	L7586	D4	R2147	L8	R7544	D8			
C2128	N7	C2472	L3	C6024	S3	F2000	C8	L7587	D4	R2148	L8	R7560	D7		
C2129	M7	C2480	K3	C6200	S7	G	L7588	E3	R2150	R3	R7820	I4			
C2131	M7	C2481	K3	C6201	S8	G2200	N8	L7590	F5	R2151	S3	S			
C2133	L8	C2482	K3	C6202	T7	G6200	T7	L7591	D8	R2166	B3	S2549	U7		
C2135	S7	C2483	K4	C6203	S8	G6450	P2	L7592	E5	R2167	B2	T			
C2137	S7	C2484	K2	C6204	T7	G7501	F2	L7604	H3	R2200	J6	T7502	F5		
C2139	M7	C2485	K4	C6205	R7	J	M	R2210	L5	T7580	D4				
C2140	N7	C2486	K4	C6206	S8	J6201	S9	M2110	O4	R2300	D7	V			
C2141	N6	C2487	K3	C6207	S7	J6202	R9	R2303	J2	V1001	O2				
C2142	M6	C2488	K2	C6208	S6	L	N1007	N3	R2405	M2	V1002	O2			
C2143	M7	C2498	J2	C6209	R8	L1001	N3	N1400	N5	R2450	J3	V1050	P1		
C2144	M7	C2499	J2	C6210	S8	L1002	O3	N1402	M3	R2480	J3	V3300	P7		
C2148	M8	C2501	H2	C6211	T7	L1405	M4	N1403	M4	R2481	L3	V3301	P7		
C2149	M8	C2506	H1	C6212	R7	L1408	O5	N1404	N6	R2482	L3	X			
C2150	L5	C2600	K9	C6213	E2	L1409	O5	N1449	M6	R2485	L3	X1450	Q5		
C2151	L5	C2601	K9	C6450	P1	L2000	D8	N1450	T3	R2500	T3	X1499	O2		
C2152	L5	C2602	K9	C6502	L6	L2002	K5	N2003	S7	R2538	H4	X2060	E1		
C2153	L5	C2603	L9	C6503	L7	L2009	T6	N2120	L6	R2543	G4	X2070	E7		

